

100

| | i | Mc [kNm] | | | | n _{1max} [min ⁻¹] | Pt [kW] | Kg | | | | |
|---------------|---------|--------------------|--------------------|--------------------|--------------------|---|------------|----|----|-----|----|----|
| | | n ₂ x h | n ₂ x h | n ₂ x h | n ₂ x h | | | M | P | CPC | F | FS |
| | | 10.000 | 20.000 | 50.000 | 100.000 | | | | | | | |
| PG 101 | 3.56 | 1.24 | 1.10 | 0.94 | 0.83 | 2800 | 12 | 13 | 15 | 18 | 11 | 14 |
| | 4.29 | 1.24 | 1.10 | 0.94 | 0.83 | | | | | | | |
| | 5.60 | 0.90 | 0.80 | 0.68 | 0.60 | | | | | | | |
| | 6.75 | 0.79 | 0.70 | 0.60 | 0.53 | | | | | | | |
| | 8.67 | 0.51 | 0.45 | 0.38 | 0.34 | | | | | | | |
| PG 102 | 12.64 | 1.24 | 1.10 | 0.94 | 0.83 | 2800 | 8 | 19 | 21 | 24 | 17 | 20 |
| | 15.24 | 1.24 | 1.10 | 0.94 | 0.83 | | | | | | | |
| | 19.91 | 1.24 | 1.10 | 0.94 | 0.83 | | | | | | | |
| | 24.00 | 1.24 | 1.10 | 0.94 | 0.83 | | | | | | | |
| | 28.93 | 1.24 | 1.10 | 0.94 | 0.83 | | | | | | | |
| | 31.36 | 0.90 | 0.80 | 0.68 | 0.60 | | | | | | | |
| | 37.14 | 1.24 | 1.10 | 0.94 | 0.83 | | | | | | | |
| | 48.53 | 0.90 | 0.80 | 0.68 | 0.60 | | | | | | | |
| | 58.50 | 0.79 | 0.70 | 0.60 | 0.53 | | | | | | | |
| PG 103 | 54.18 | 1.24 | 1.10 | 0.94 | 0.83 | 2800 | 5 | 25 | 27 | 30 | 23 | 26 |
| | 65.31 | 1.24 | 1.10 | 0.94 | 0.83 | | | | | | | |
| | 70.80 | 1.24 | 1.10 | 0.94 | 0.83 | | | | | | | |
| | 78.72 | 1.24 | 1.10 | 0.94 | 0.83 | | | | | | | |
| | 85.33 | 1.24 | 1.10 | 0.94 | 0.83 | | | | | | | |
| | 102.86 | 1.24 | 1.10 | 0.94 | 0.83 | | | | | | | |
| | 111.50 | 1.24 | 1.10 | 0.94 | 0.83 | | | | | | | |
| | 134.40 | 1.24 | 1.10 | 0.94 | 0.83 | | | | | | | |
| | 162.00 | 1.24 | 1.10 | 0.94 | 0.83 | | | | | | | |
| | 172.56 | 1.24 | 1.10 | 0.94 | 0.83 | | | | | | | |
| | 208.00 | 1.24 | 1.10 | 0.94 | 0.83 | | | | | | | |
| | 211.68 | 0.90 | 0.80 | 0.68 | 0.60 | | | | | | | |
| | 255.15 | 0.90 | 0.80 | 0.68 | 0.60 | | | | | | | |
| | 271.79 | 0.90 | 0.80 | 0.68 | 0.60 | | | | | | | |
| | 307.55 | 0.79 | 0.70 | 0.60 | 0.53 | | | | | | | |
| | 321.90 | 1.24 | 1.10 | 0.94 | 0.83 | | | | | | | |
| 394.88 | 0.79 | 0.70 | 0.60 | 0.53 | | | | | | | | |
| PG 104 | 337.36 | 1.24 | 1.10 | 0.94 | 0.83 | 2800 | 1.5 | 31 | 33 | 36 | 29 | 32 |
| | 365.71 | 1.24 | 1.10 | 0.94 | 0.83 | | | | | | | |
| | 396.45 | 1.24 | 1.10 | 0.94 | 0.83 | | | | | | | |
| | 440.82 | 1.24 | 1.10 | 0.94 | 0.83 | | | | | | | |
| | 477.87 | 1.24 | 1.10 | 0.94 | 0.83 | | | | | | | |
| | 531.34 | 1.24 | 1.10 | 0.94 | 0.83 | | | | | | | |
| | 576.00 | 1.24 | 1.10 | 0.94 | 0.83 | | | | | | | |
| | 624.41 | 1.24 | 1.10 | 0.94 | 0.83 | | | | | | | |
| | 694.29 | 1.24 | 1.10 | 0.94 | 0.83 | | | | | | | |
| | 752.64 | 1.24 | 1.10 | 0.94 | 0.83 | | | | | | | |
| | 836.86 | 1.24 | 1.10 | 0.94 | 0.83 | | | | | | | |
| | 907.20 | 1.24 | 1.10 | 0.94 | 0.83 | | | | | | | |
| | 966.35 | 1.24 | 1.10 | 0.94 | 0.83 | | | | | | | |
| | 1093.50 | 1.24 | 1.10 | 0.94 | 0.83 | | | | | | | |
| | 1144.55 | 1.24 | 1.10 | 0.94 | 0.83 | | | | | | | |
| | 1185.41 | 0.90 | 0.80 | 0.68 | 0.60 | | | | | | | |
| | 1318.06 | 1.24 | 1.10 | 0.94 | 0.83 | | | | | | | |
| | 1428.84 | 0.90 | 0.80 | 0.68 | 0.60 | | | | | | | |
| | 1692.32 | 1.24 | 1.10 | 0.94 | 0.83 | | | | | | | |
| | 3422.25 | 0.79 | 0.70 | 0.60 | 0.53 | | | | | | | |

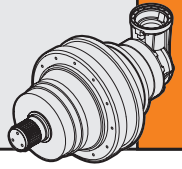

| | i | Mc [kNm] | | | | n _{1max} [min ⁻¹] | Pt [kW] | Kg | | | | | | | | | | | | |
|----------------|----------------|--------------------|--------------------|--------------------|--------------------|---|------------|----|----|-----|----|----|------|------|-----|----|----|----|----|----|
| | | n ₂ x h | n ₂ x h | n ₂ x h | n ₂ x h | | | M | P | CPC | F | FS | | | | | | | | |
| | | 10.000 | 20.000 | 50.000 | 100.000 | | | | | | | | | | | | | | | |
| PGA 102 | 10.41 | 1.24 | 1.10 | 0.94 | 0.83 | 2800 | 8 | 28 | 30 | 33 | 26 | 29 | | | | | | | | |
| | 12.55 | 1.24 | 1.10 | 0.94 | 0.83 | | | | | | | | | | | | | | | |
| | 16.40 | 0.90 | 0.80 | 0.68 | 0.60 | | | | | | | | | | | | | | | |
| | 19.77 | 0.79 | 0.70 | 0.60 | 0.53 | | | | | | | | | | | | | | | |
| PGA 103 | 37.02 | 1.24 | 1.10 | 0.94 | 0.83 | 2800 | 5 | 34 | 36 | 39 | 32 | 35 | | | | | | | | |
| | 44.63 | 1.24 | 1.10 | 0.94 | 0.83 | | | | | | | | | | | | | | | |
| | 53.79 | 1.24 | 1.10 | 0.94 | 0.83 | | | | | | | | | | | | | | | |
| | 58.31 | 1.24 | 1.10 | 0.94 | 0.83 | | | | | | | | | | | | | | | |
| | 70.29 | 1.24 | 1.10 | 0.94 | 0.83 | | | | | | | | | | | | | | | |
| | 84.72 | 1.24 | 1.10 | 0.94 | 0.83 | | | | | | | | | | | | | | | |
| | 90.24 | 1.24 | 1.10 | 0.94 | 0.83 | | | | | | | | | | | | | | | |
| | 108.78 | 1.24 | 1.10 | 0.94 | 0.83 | | | | | | | | | | | | | | | |
| | 133.43 | 0.79 | 0.70 | 0.60 | 0.53 | | | | | | | | | | | | | | | |
| | 142.13 | 0.90 | 0.80 | 0.68 | 0.60 | | | | | | | | | | | | | | | |
| | 171.32 | 0.79 | 0.70 | 0.60 | 0.53 | | | | | | | | | | | | | | | |
| | PGA 104 | 131.64 | 1.24 | 1.10 | 0.94 | | | | | | | | 0.83 | 2800 | 1.5 | 40 | 42 | 45 | 38 | 41 |
| | | 158.67 | 1.24 | 1.10 | 0.94 | | | | | | | | 0.83 | | | | | | | |
| 191.25 | | 1.24 | 1.10 | 0.94 | 0.83 | | | | | | | | | | | | | | | |
| 207.33 | | 1.24 | 1.10 | 0.94 | 0.83 | | | | | | | | | | | | | | | |
| 230.53 | | 1.24 | 1.10 | 0.94 | 0.83 | | | | | | | | | | | | | | | |
| 301.22 | | 1.24 | 1.10 | 0.94 | 0.83 | | | | | | | | | | | | | | | |
| 326.54 | | 1.24 | 1.10 | 0.94 | 0.83 | | | | | | | | | | | | | | | |
| 363.08 | | 1.24 | 1.10 | 0.94 | 0.83 | | | | | | | | | | | | | | | |
| 393.60 | | 1.24 | 1.10 | 0.94 | 0.83 | | | | | | | | | | | | | | | |
| 474.43 | | 1.24 | 1.10 | 0.94 | 0.83 | | | | | | | | | | | | | | | |
| 514.30 | | 0.90 | 0.80 | 0.68 | 0.60 | | | | | | | | | | | | | | | |
| 571.86 | | 1.24 | 1.10 | 0.94 | 0.83 | | | | | | | | | | | | | | | |
| 609.14 | | 1.24 | 1.10 | 0.94 | 0.83 | | | | | | | | | | | | | | | |
| 734.23 | | 1.24 | 1.10 | 0.94 | 0.83 | | | | | | | | | | | | | | | |
| 782.11 | | 1.24 | 1.10 | 0.94 | 0.83 | | | | | | | | | | | | | | | |
| 942.72 | | 1.24 | 1.10 | 0.94 | 0.83 | | | | | | | | | | | | | | | |
| 1156.42 | | 0.79 | 0.70 | 0.60 | 0.53 | | | | | | | | | | | | | | | |
| 1231.82 | | 0.90 | 0.80 | 0.68 | 0.60 | | | | | | | | | | | | | | | |
| 1484.79 | | 0.79 | 0.70 | 0.60 | 0.53 | | | | | | | | | | | | | | | |



$$M_{\max} = M_c \times 2$$

(n₂ x h = 20.000)

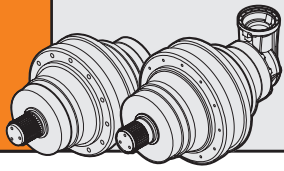

100

MS

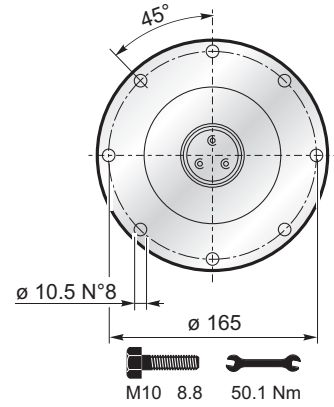
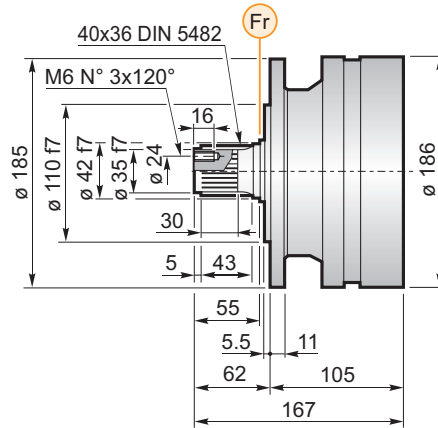
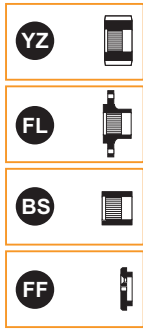

MC

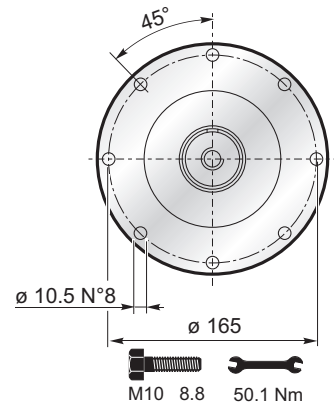
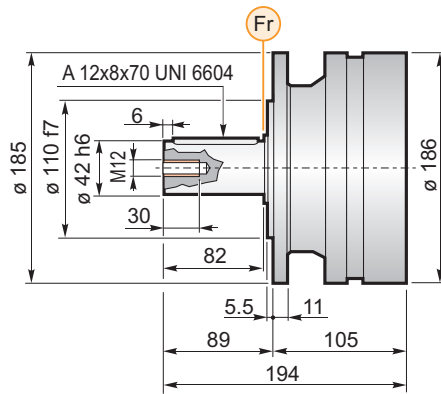

PS

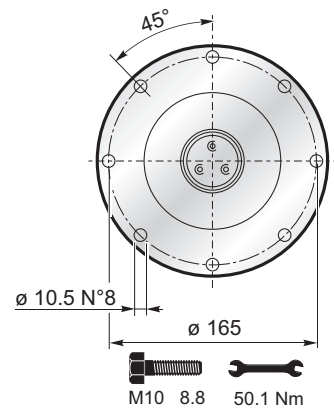
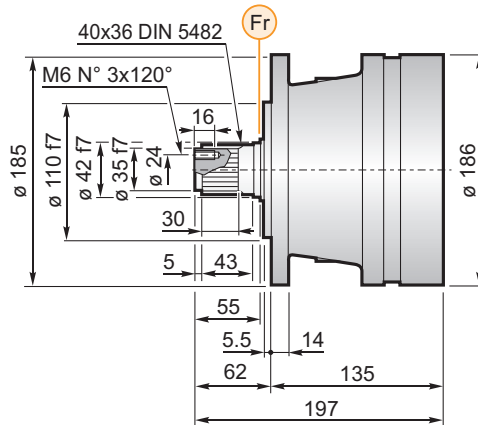
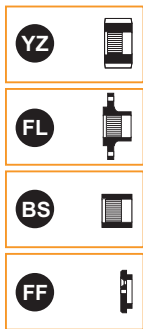

PC

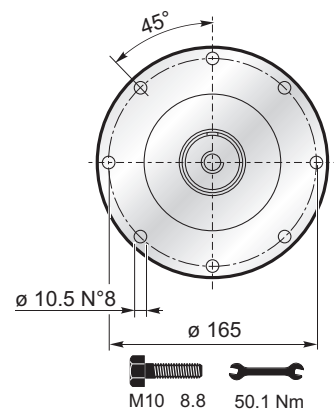
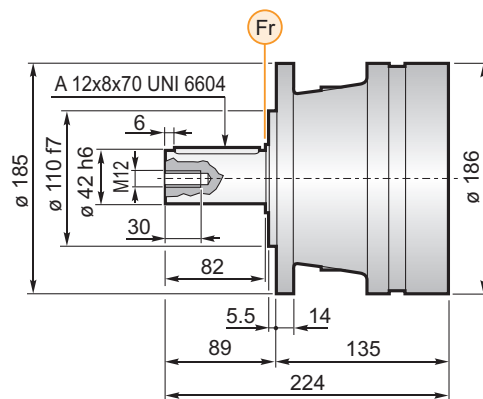

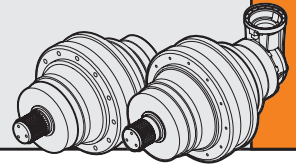

F

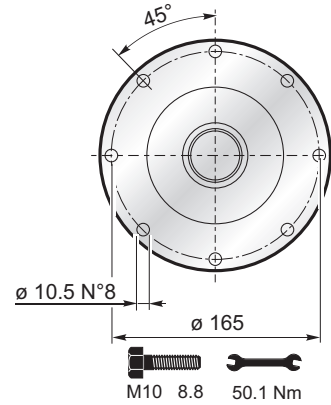
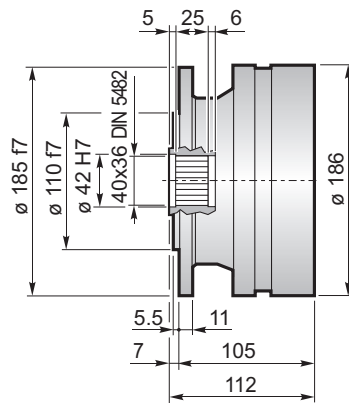

FS

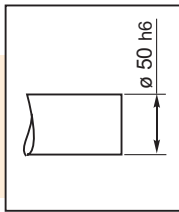
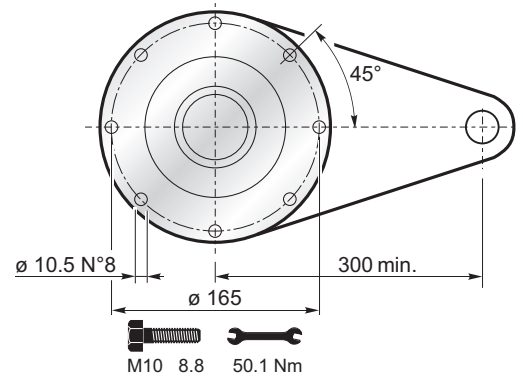
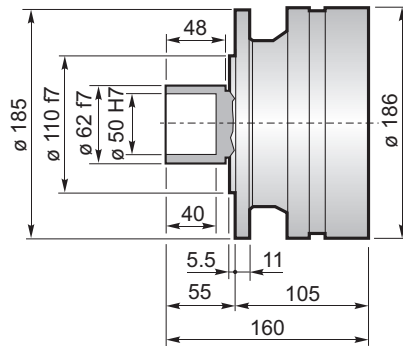

$M_{max} = 2.2 \text{ kNm}$

La coppia massima indicata è valida solo con calettatori forniti da Planetary Drives
 The maximum torque indicated is valid only with shrink discs supplied by Planetary Drives
 Das dargestellte, maximale Drehmoment gilt nur mit von Planetary Drives gelieferter Schrumpfscheibe
 Le couple maximal indiqué n'est valable qu'avec les frettes de serrage fournis par Planetary Drives
 El momento máximo indicado sólo es válido con discos de contracción suministrados por Planetary Drives
 O torque máximo indicado é válido exclusivamente com discos de contração fornecidos pela Planetary Drives

CPC

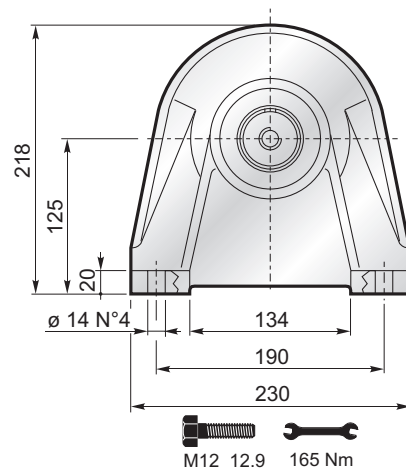
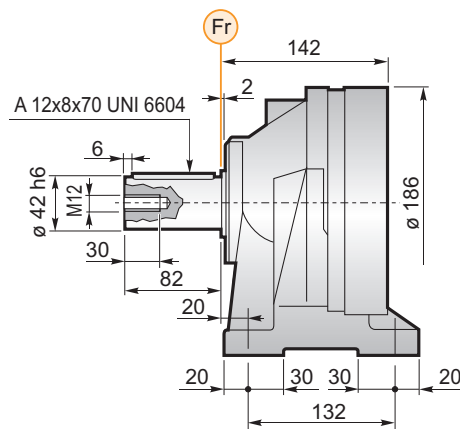

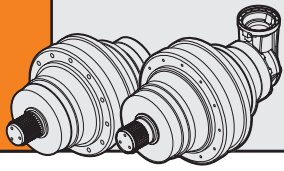

100

PE

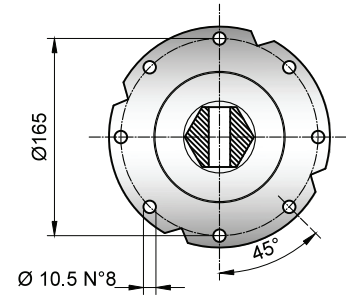
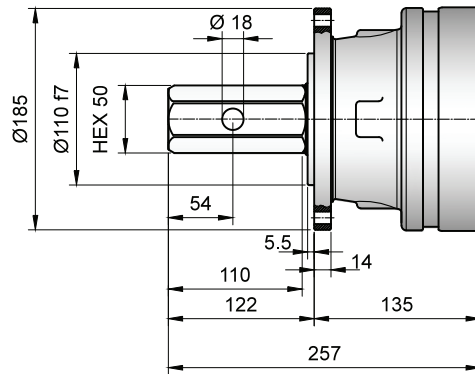

MCT

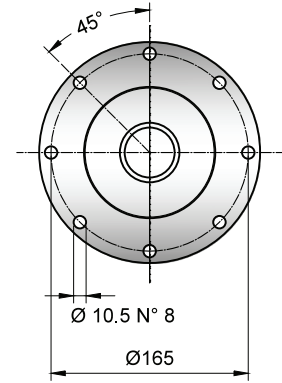
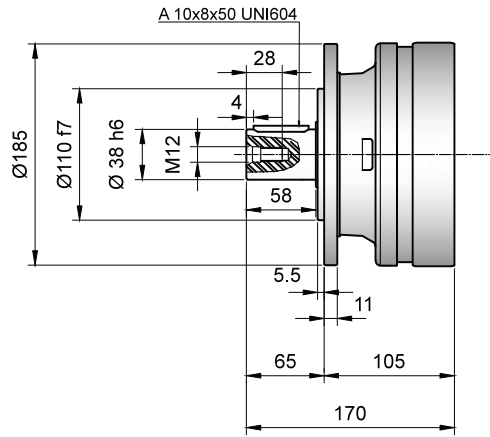

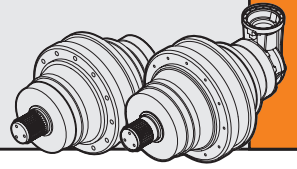



| | PG ...MS | | | | | |
|--------|----------|-----|----|----|----|-----|
| | A | B | RA | RB | EF | EDF |
| PG 101 | 105 | 167 | • | | | • |
| PG 102 | 153 | 215 | • | | | • |
| PG 103 | 201 | 263 | • | | | • |
| PG 104 | 249 | 311 | • | | | • |

| | PG ...MC | | | | | |
|--------|----------|-----|----|----|----|-----|
| | A | B | RA | RB | EF | EDF |
| PG 101 | 105 | 194 | • | | | • |
| PG 102 | 153 | 242 | • | | | • |
| PG 103 | 201 | 290 | • | | | • |
| PG 104 | 249 | 338 | • | | | • |

| | PG ...PS | | | | | |
|--------|----------|-----|----|----|----|-----|
| | A | B | RA | RB | EF | EDF |
| PG 101 | 135 | 197 | • | | | • |
| PG 102 | 183 | 245 | • | | | • |
| PG 103 | 231 | 293 | • | | | • |
| PG 104 | 271 | 341 | • | | | • |

| | PG ...PC | | | | | |
|--------|----------|-----|----|----|----|-----|
| | A | B | RA | RB | EF | EDF |
| PG 101 | 135 | 224 | • | | | • |
| PG 102 | 183 | 272 | • | | | • |
| PG 103 | 231 | 320 | • | | | • |
| PG 104 | 279 | 368 | • | | | • |

| | PG ...F | | | | | |
|--------|---------|-----|----|----|----|-----|
| | A | B | RA | RB | EF | EDF |
| PG 101 | 105 | 112 | • | | | • |
| PG 102 | 153 | 160 | • | | | • |
| PG 103 | 201 | 208 | • | | | • |
| PG 104 | 249 | 256 | • | | | • |

| | PG ...FS | | | | | |
|--------|----------|-----|----|----|----|-----|
| | A | B | RA | RB | EF | EDF |
| PG 101 | 105 | 160 | • | | | • |
| PG 102 | 153 | 208 | • | | | • |
| PG 103 | 201 | 256 | • | | | • |
| PG 104 | 249 | 304 | • | | | • |

| | PG ...CPC | | | | | |
|--------|-----------|-----|----|----|----|-----|
| | A | B | RA | RB | EF | EDF |
| PG 101 | 142 | 224 | • | | | • |
| PG 102 | 190 | 272 | • | | | • |
| PG 103 | 238 | 320 | • | | | • |
| PG 104 | 287 | 368 | • | | | • |

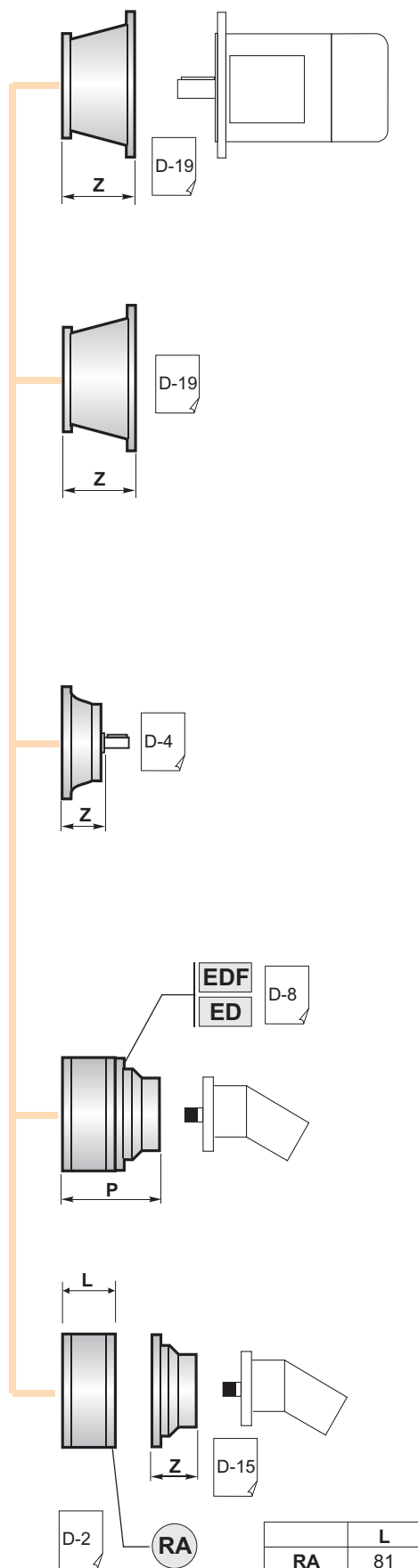

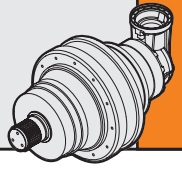

| | PGA ...MS | | | | |
|---------|-----------|-----|----|----|----|
| | A | B | RA | RB | EF |
| PGA 102 | 180 | 159 | • | • | • |
| PGA 103 | 228 | 159 | • | • | • |
| PGA 104 | 276 | 159 | • | • | • |

| | PGA ...MC | | | | |
|---------|-----------|-----|----|----|----|
| | A | B | RA | RB | EF |
| PGA 102 | 180 | 159 | • | • | • |
| PGA 103 | 228 | 159 | • | • | • |
| PGA 104 | 276 | 159 | • | • | • |

| | PGA ...PS | | | | |
|---------|-----------|-----|----|----|----|
| | A | B | RA | RB | EF |
| PGA 102 | 210 | 159 | • | • | • |
| PGA 103 | 258 | 159 | • | • | • |
| PGA 104 | 306 | 159 | • | • | • |

| | PGA ...PC | | | | |
|---------|-----------|-----|----|----|----|
| | A | B | RA | RB | EF |
| PGA 102 | 210 | 159 | • | • | • |
| PGA 103 | 258 | 159 | • | • | • |
| PGA 104 | 306 | 159 | • | • | • |

| | PGA ...F | | | | |
|---------|----------|-----|----|----|----|
| | A | B | RA | RB | EF |
| PGA 102 | 180 | 159 | • | • | • |
| PGA 103 | 228 | 159 | • | • | • |
| PGA 104 | 276 | 159 | • | • | • |

| | PGA ...FS | | | | |
|---------|-----------|-----|----|----|----|
| | A | B | RA | RB | EF |
| PGA 102 | 180 | 159 | • | • | • |
| PGA 103 | 228 | 159 | • | • | • |
| PGA 104 | 276 | 159 | • | • | • |

| | PGA ...CPC | | | | |
|---------|------------|-----|----|----|----|
| | A | B | RA | RB | EF |
| PGA 102 | 217 | 159 | • | • | • |
| PGA 103 | 265 | 159 | • | • | • |
| PGA 104 | 313 | 159 | • | • | • |

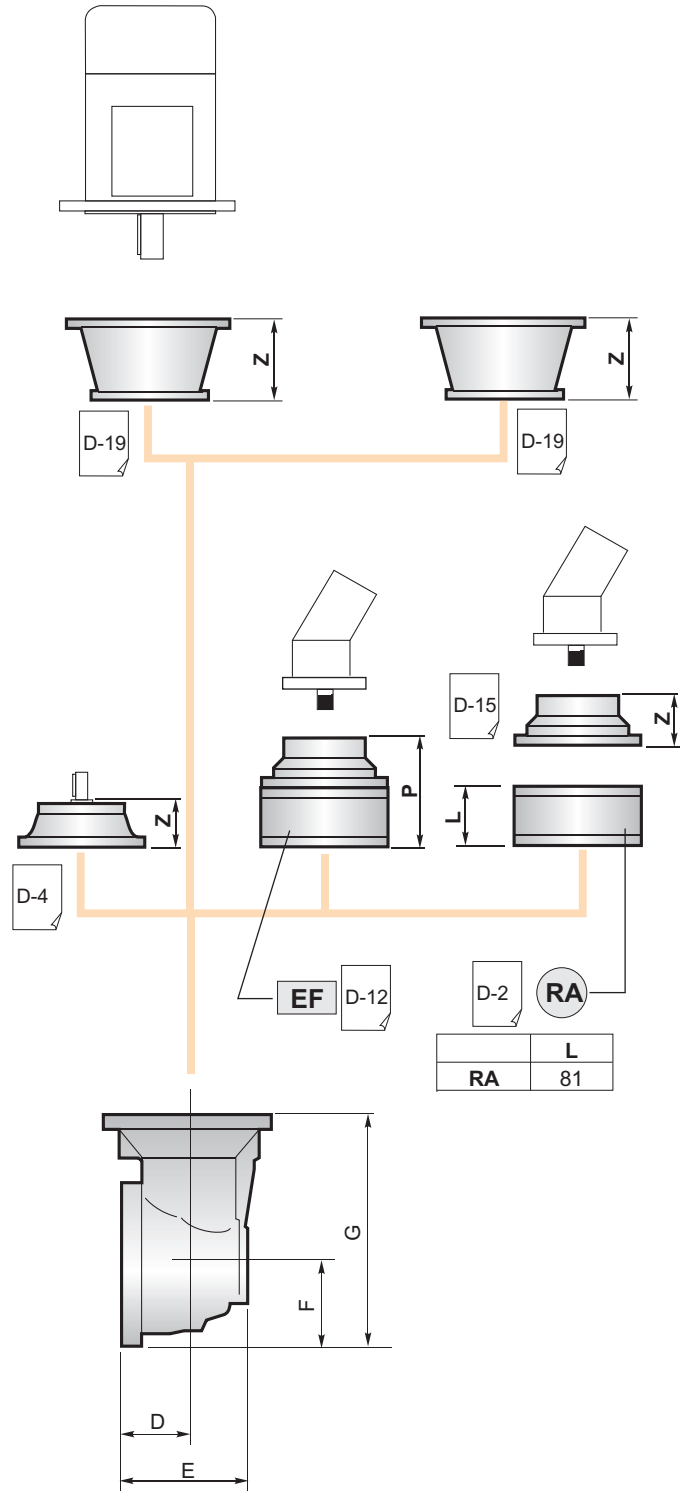

| | D | E | F | G |
|---------|----|-------|----|-----|
| PGA 102 | 75 | 141.5 | 93 | 252 |
| PGA 103 | 75 | 141.5 | 93 | 252 |
| PGA 104 | 75 | 141.5 | 93 | 252 |

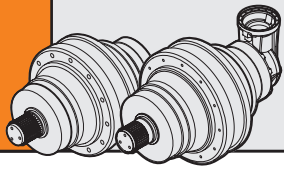

100

YZ Pignoni / Pinion
Ritzel / Pignon
Piñones / Pinhões

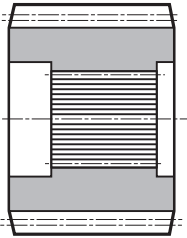

Su richiesta / On request
Auf Anfrage / Sur demande
Bajo demanda / Sob consulta

FF Fondello di arresto / Stop bottom plate
Endscheibe / Bouchon de fermeture
Tapón de detención / Fundo de batente

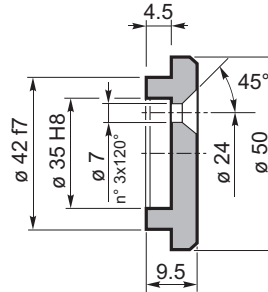

Codice / Code
Bestell - Nr. / Code
Código / Código
5701.034.000

BS Boccola scanalata / Splined bushing
Innenverzahnte Buchse / Moyeu cannelé
Casquillo ranurado / Bucha estriada

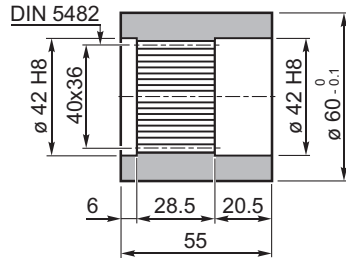

Materiale / Material
Material / Matière
Material / Material
UNI C40
SAE 1040
DIN Ck40

Codice / Code
Bestell - Nr. / Code
Código / Código
1710.100.076

KB Barra scanalata / Splined rod
Außenverzahnte Welle / Arbre cannelé
Barra ranurada / Barra estriada

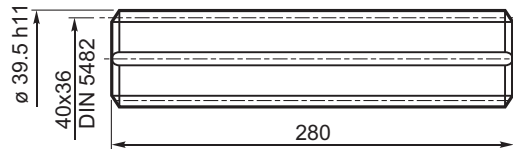

Materiale / Material
Material / Matière
Material / Material

UNI 39NiCrMo3
bonificato / hardened and tempered
vergütet / bonifié
bonificado / endurecido e temperado

Codice / Code
Bestell - Nr. / Code
Código / Código
1703.179.042

FL Flangia / Flange
Flansch / Bride
Brida / Flange

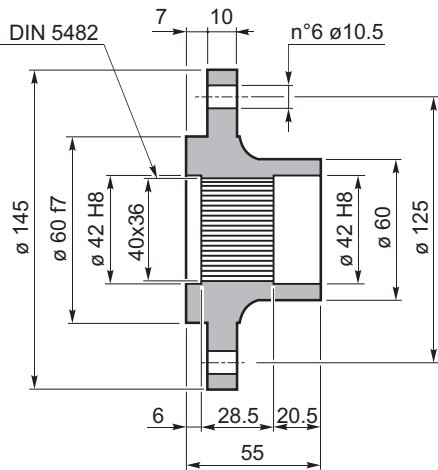

Codice / Code
Bestell - Nr. / Code
Código / Código
1710.102.025

GA Giunto di attrito / Shrink disc
Schrumpfscheibe / Frette de serrage
Disco de contracción / Disco de contração

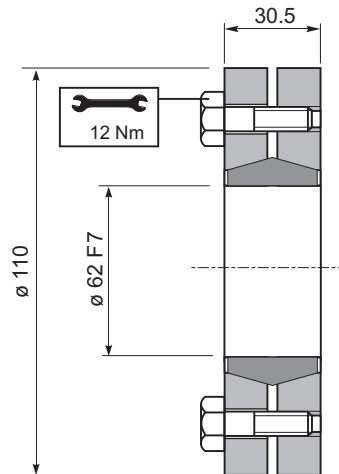

Coppia max.
Max. torque
Max. Drehmoment
Couple max.
Momento máx.
Torque máx.
2.2 kNm

Codice / Code
Bestell - Nr. / Code
Código / Código
9015.062.000

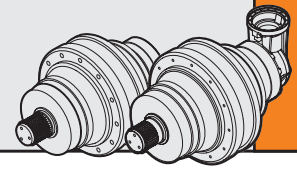

CARICHI RADIALI (Fr)

Nei diagrammi seguenti sono riportati i carichi radiali e i coefficienti K per rapportarli al valore $n_2 \times h$ desiderato.

RADIAL LOADS (Fr)

The following curves show the radial loads and the K factors to obtain the required $n_2 \times h$ value.

RADIALLAST (Fr)

In den nachstehenden Diagrammen ist die Radiallast und der Koeffizient K dargestellt und kann mit dem gewünschten Wert $n_2 \times h$ verglichen werden.

CHARGES RADIALES (Fr)

Dans les diagrammes suivants sont indiqués les charges radiales et les facteurs K de façon à obtenir la valeur $n_2 \times h$ désirée.

CARGAS RADIALES (Fr)

En los siguientes diagramas se indican las cargas radiales y los coeficientes K para obtener el valor requerido $n_2 \times h$.

CARGAS RADIAIS (Fr)

Nos diagramas seguintes são indicadas as cargas radiais e os coeficientes K para obter o valor $n_2 \times h$ desejado.

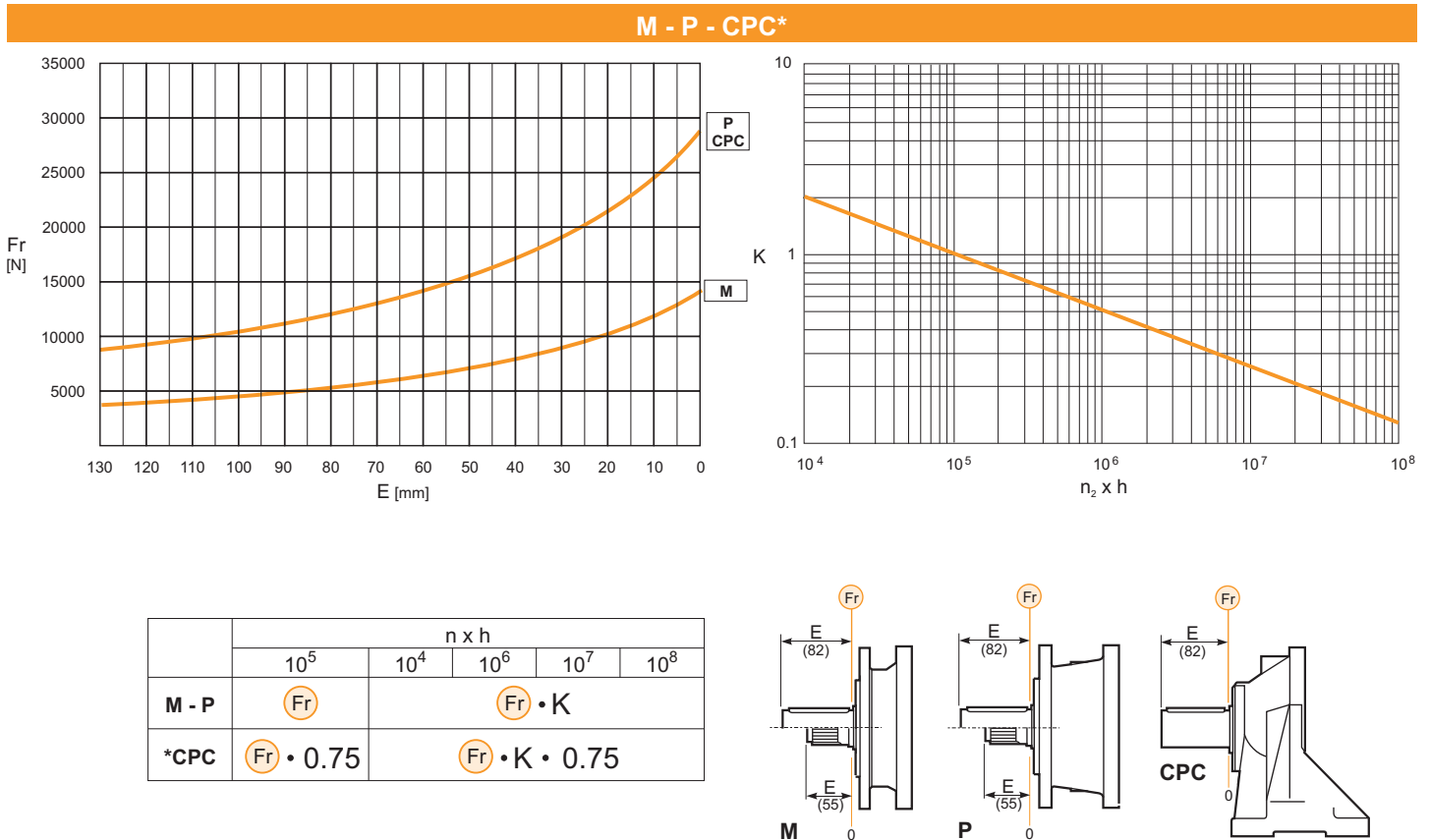

CARICHI ASSIALI (Fa)

I valori dei carichi assiali indicati in tabella sono riferiti alle versioni e alla direzione di applicazione del carico.

AXIAL LOADS (Fa)

The values of the axial loads in the table refer to the output versions and load direction of application.

AXIALLAST (Fa)

Die dargestellten Werte der Axiallast basieren auf der Version und der applizierten Lastrichtung.

CHARGES AXIALES (Fa)

Les valeurs des charges axiales indiquées dans le tableau se réfèrent aux versions et à la direction d'application de la charge.

CARGAS AXIALES (Fa)

Los valores de las cargas axiales indicados en la tabla se refieren a las versiones y a la dirección de aplicación de la carga.

CARGAS AXIAIS (Fa)

Os valores das cargas axiais indicadas na tabela referem-se às versões e à direção de aplicação da carga.

| Fa [N] | M | P - CPC | |
|-----------|-------|---------|-------|
| | | 16000 | 18000 |
| | 16000 | 18000 | → |

